

# X13061

## POSEIDON HEATED-ROLL IRONER

ARCHITECTURAL/MECHANICAL  
PRODUCT SPECIFICATIONS

### PRODUCT SPECS

Cylinder Diameter <i>inch</i>	12.8	
Usable Cylinder Width <i>inch</i>	60.6	
Evaporation Capability <i>gal/h</i>	3.96	
Ironing Speed <i>ft/min</i>	3-36	
Net Weight <i>lbs</i>	1012	
Crated Weight <i>lbs</i>	1360	
Machine Width <i>inch</i>	91.1	
Machine Depth <i>inch</i>	34.3	
Machine Height <i>inch</i>	55.7	
Feed Height <i>inch</i>	39.2	
Shipping Dimensions <i>inch</i> (WxDxH)	96.4 x 35.6 x 63	
Motor Power <i>Hp</i>		
Roller Motor	0.40	
Extraction Motor	0.40	
Exhaust Diameter <i>inch</i>	4.5	
Exhaust Air Flow <i>cfm</i>		
Gas	387	
Electric	353	
Electric Heating <i>kW</i>		
208/60/3	12.39	
240/60/3	16.5	
Gas Connection <i>inch</i>	3/4 NPT	
Gas Heating <i>BTU/h</i>		
Natural	79,844	
Propane	76,773	
Gas Consumption <i>cfm</i>		
Natural	1.46	
Propane	3.78	
Gas Supply Pressure <i>inch wc</i>		
Natural	7	
Propane	11	
Circuit Protection <i>Amps</i>		
Gas	208-240/60/1	10
Electric	208/60/3	70
	240/60/3	70
Full Load <i>Amps</i>		
Gas	208-240/60/1	4.7
Electric	208/60/3	39
	240/60/3	44

FRONT VIEW

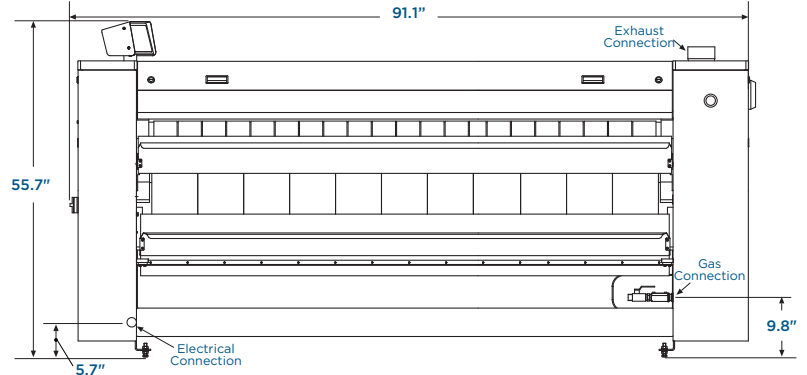

TOP VIEW

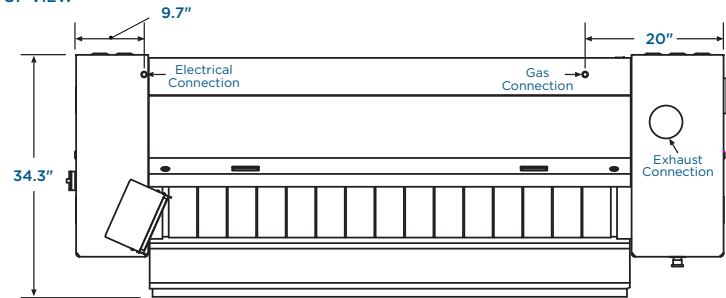

AREA NEEDED FOR SERVICE

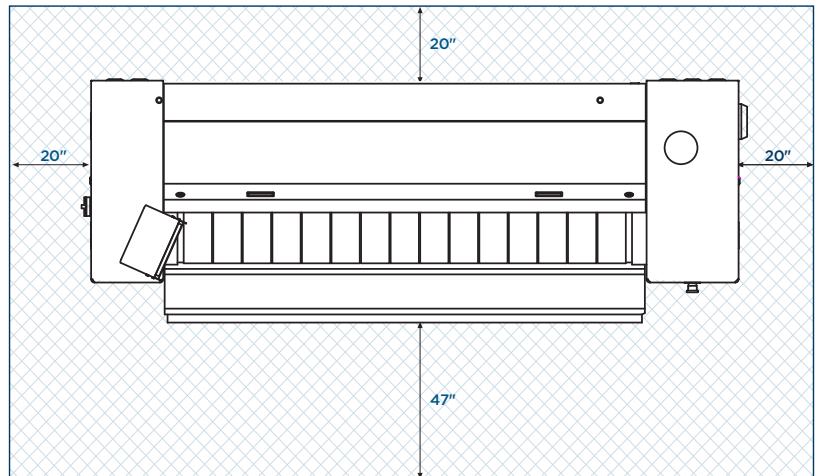

SIDE VIEW

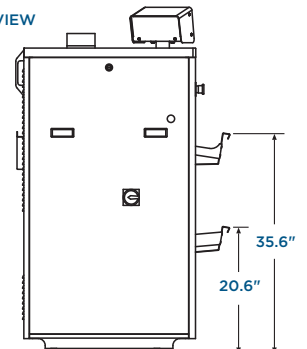

\* Specifications subject to change without notice or obligation. Contact Poseidon Textile Care Systems at (800) 482-3400 for dimensions not shown or for clarification.

poseidonwetcleaning.com • (800) 482-3400  
2329 Alger Drive, Troy, MI 48083



# X13084

## POSEIDON HEATED-ROLL IRONER

ARCHITECTURAL/MECHANICAL  
PRODUCT SPECIFICATIONS

### PRODUCT SPECS

Cylinder Diameter <i>inch</i>	12.8
Usable Cylinder Width <i>inch</i>	83.5
Evaporation Capability <i>gal/h</i>	5.28
Ironing Speed <i>ft/min</i>	3-36
Net Weight <i>lbs</i>	1237
Crated Weight <i>lbs</i>	1630
Machine Width <i>inch</i>	114
Machine Depth <i>inch</i>	34.3
Machine Height <i>inch</i>	55.7
Feed Height <i>inch</i>	39.2
Shipping Dimensions <i>inch</i> (WxDxH)	119.5 x 35.6 x 63
Motor Power <i>Hp</i>	
Roller Motor	0.40
Extraction Motor	0.40
Exhaust Diameter <i>inch</i>	4.5
Exhaust Air Flow <i>cfm</i>	
Gas	387
Electric	353
Electric Heating <i>kW</i>	
208/60/3	17.44
240/60/3	23.22
Gas Connection <i>inch</i>	3/4 NPT
Gas Heating <i>BTU/h</i>	
Natural	98,611
Propane	102,705
Gas Consumption <i>cfm</i>	
Natural	1.8
Propane	5.06
Gas Supply Pressure <i>inch wc</i>	
Natural	7
Propane	11
Circuit Protection <i>Amps</i>	
Gas 208-240/60/1	10
Electric 208/60/3	80
240/60/3	80
Full Load <i>Amps</i>	
Gas 208-240/60/1	4.7
Electric 208/60/3	53
240/60/3	61

FRONT VIEW

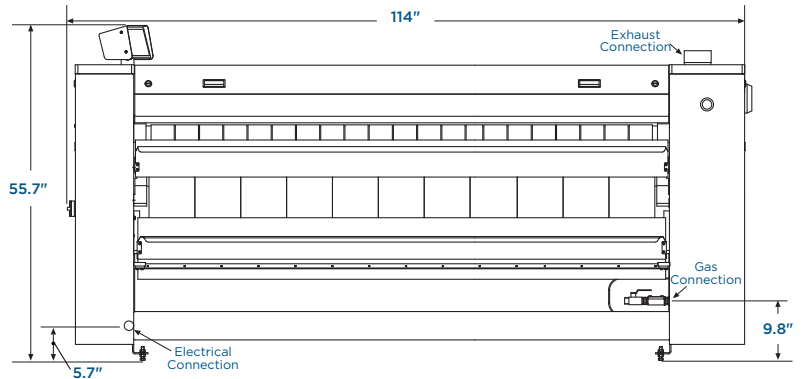

TOP VIEW

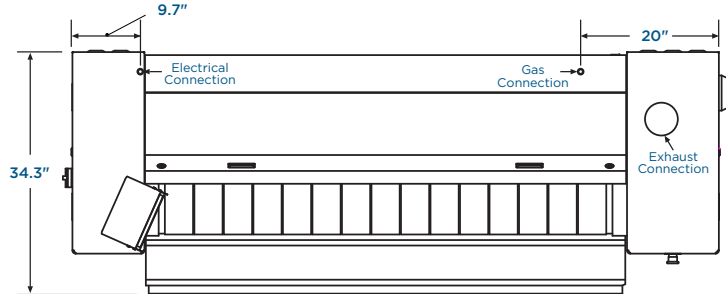

AREA NEEDED FOR SERVICE

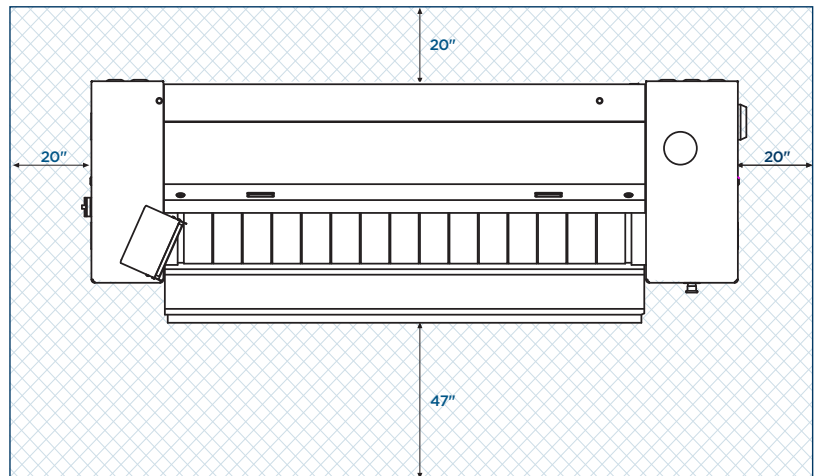

SIDE VIEW

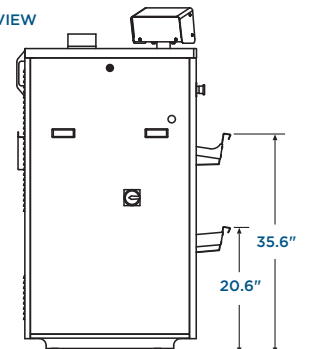

\* Specifications subject to change without notice or obligation. Contact Poseidon Textile Care Systems at (800) 482-3400 for dimensions not shown or for clarification.

poseidonwetcleaning.com • (800) 482-3400  
2329 Alger Drive, Troy, MI 48083



# X20075

## POSEIDON HEATED-ROLL IRONER

ARCHITECTURAL/MECHANICAL  
PRODUCT SPECIFICATIONS

### PRODUCT SPECS

Cylinder Diameter	inch	20.1
Usable Cylinder Width	inch	74.8
Evaporation Capability	gal/h	
Gas/Electric		7.93
Steam		11.1
Ironing Speed	ft/min	4-49
Net Weight	lbs	
Gas/Electric	without folder	2282
	with folder	2496
Steam	without folder	2525
	with folder	2739
Crated Weight	lbs	
Gas/Electric	without folder	2834
	with folder	3080
Steam	without folder	3076
	with folder	3323
Machine Width	inch	111.7
Machine Depth	inch	46.2
Machine Height	inch	64.2
Feed Height	inch	40.6
Shipping Dimensions (WxDxH)	inch	
	without folder	117.6 x 45.5 x 71.9
	with folder	117.6 x 50.6 x 71.9
Motor Power	Hp	
Roller Motor		0.40
Extraction Motor		0.74
Exhaust Diameter	inch	5.1
Exhaust Air Flow	cfm	
Gas		564
Electric/Steam		634
Electric Heating	kW	
208/60/3		28.34
240/60/3		37.73
Gas Connection	inch	3/4 NPT
Gas Heating	BTU/h	
Natural		163,100
Propane		158,323
Gas Consumption	cfm	
Natural		2.98
Propane		7.81
Gas Pressure Operating Manifold	inch wc	
Natural		7
Propane		11
Steam Connection	inch	1
Steam Condensate Outlet	inch	3/4
Steam Heating	BTU/h	166,513
Steam Consumption	lbs/h	190
Steam Pressure	PSI	116
Safety Valve Connection	inch	1
Circuit Protection	Amps	
Gas/Steam	208-240/60/1	10
Electric	208/60/3	125
	240/60/3	125
Full Load	Amps	
Gas/Steam	208-240/60/1	6.1
Electric	208/60/3	85
	240/60/3	97

### FRONT VIEW

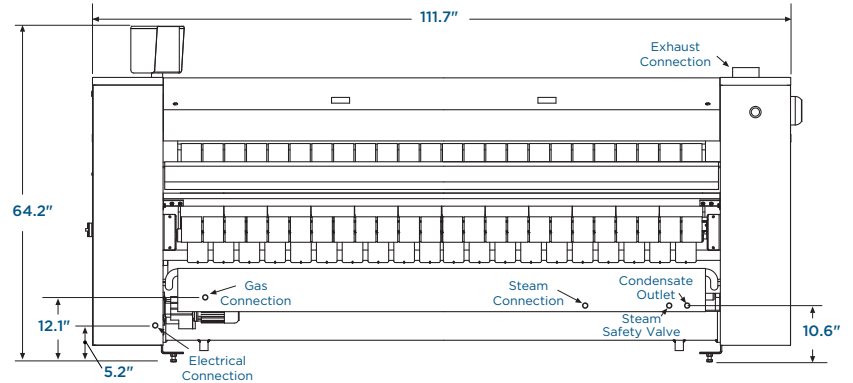

### TOP VIEW

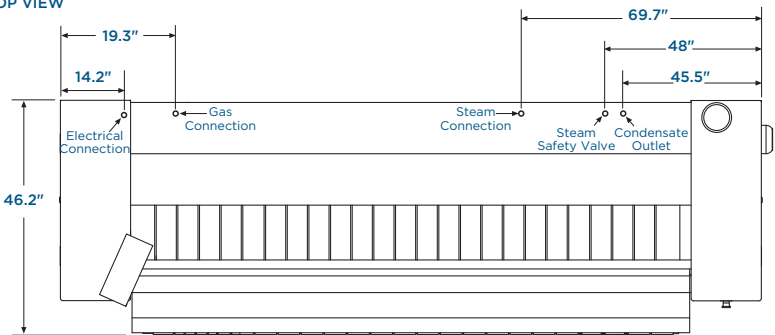

### AREA NEEDED FOR SERVICE

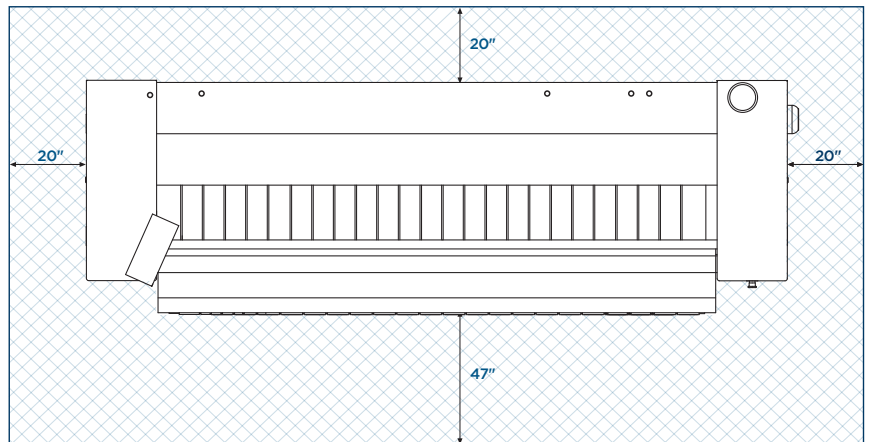

### SIDE VIEW

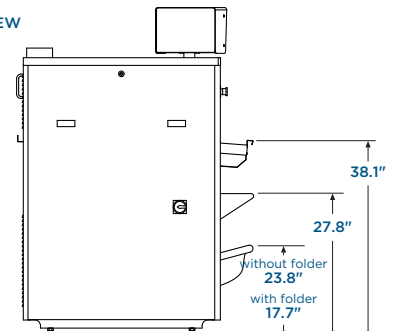

\* Specifications subject to change without notice or obligation. Contact Poseidon Textile Care Systems at (800) 482-3400 for dimensions not shown or for clarification.

poseidonwetcleaning.com • (800) 482-3400  
2329 Alger Drive, Troy, MI 48083



# X20100

## POSEIDON HEATED-ROLL IRONER

ARCHITECTURAL/MECHANICAL  
PRODUCT SPECIFICATIONS

### PRODUCT SPECS

Cylinder Diameter	inch	20.1
Usable Cylinder Width	inch	99.6
Evaporation Capability	gal/h	
Gas/Electric		10.57
Steam		14.79
Ironing Speed	ft/min	4-49
Net Weight	lbs	
Gas/Electric	without folder	2788
	with folder	3069
Steam	without folder	3031
	with folder	3312
Crated Weight	lbs	
Gas/Electric	without folder	3439
	with folder	3775
Steam	without folder	3681
	with folder	4017
Machine Width	inch	136.6
Machine Depth	inch	46.2
Machine Height	inch	64.2
Feed Height	inch	40.6
Shipping Dimensions (WxDxH)	inch	
	without folder	142.1 x 45.5 x 71.9
	with folder	142.1 x 50.6 x 71.9
Motor Power	Hp	
Roller Motor		0.40
Extraction Motor		0.74
Exhaust Diameter	inch	5.1
Exhaust Air Flow	cfm	
Gas		564
Electric/Steam		634
Electric Heating	kW	
208/60/3		37.06
240/60/3		49.34
Gas Connection	inch	3/4 NPT
Gas Heating	BTU/h	
Natural		208,823
Propane		201,999
Gas Consumption	cfm	
Natural		3.81
Propane		9.95
Gas Pressure Operating Manifold	inch wc	
Natural		7
Propane		11
Steam Connection	inch	1
Steam Condensate Outlet	inch	3/4 (19)
Steam Heating	BTU/h	221,789
Steam Consumption	lbs/h	254
Steam Pressure	PSI	116
Safety Valve Connection	inch	1
Circuit Protection	Amps	
Gas/Steam	208-240/60/1	10
Electric	208/60/3	160
	240/60/3	160
Full Load	Amps	
Gas/Steam	208-240/60/1	6.1
Electric	208/60/3	109
	240/60/3	125

### FRONT VIEW

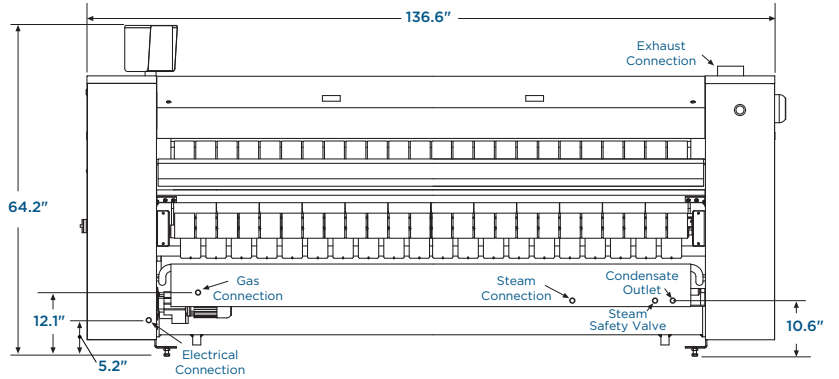

### TOP VIEW

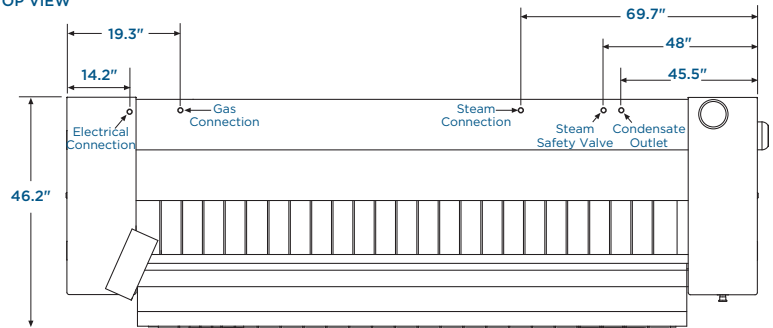

### AREA NEEDED FOR SERVICE

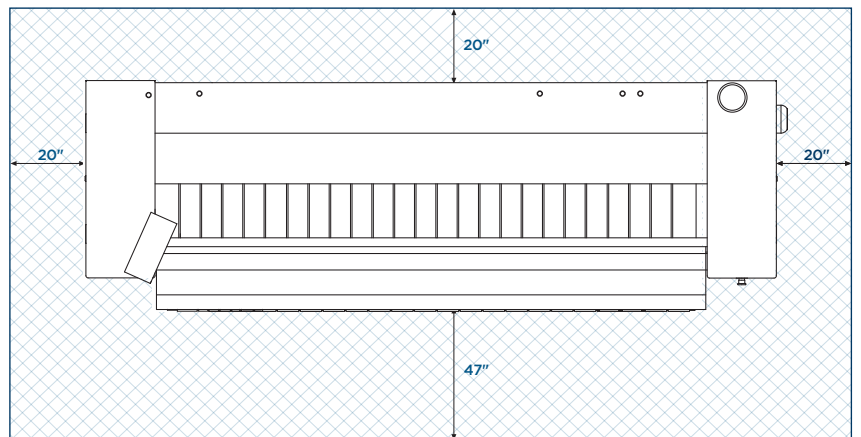

### SIDE VIEW

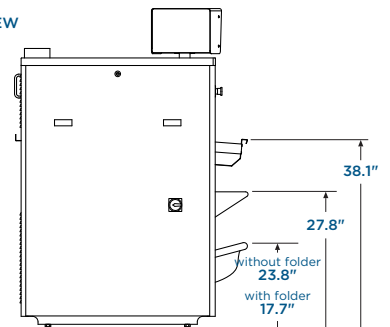

\* Specifications subject to change without notice or obligation. Contact Poseidon Textile Care Systems at (800) 482-3400 for dimensions not shown or for clarification.

poseidonwetcleaning.com • (800) 482-3400  
2329 Alger Drive, Troy, MI 48083



# X20125

## POSEIDON HEATED-ROLL IRONER

ARCHITECTURAL/MECHANICAL  
PRODUCT SPECIFICATIONS

### PRODUCT SPECS

Cylinder Diameter	inch	20.1
Usable Cylinder Width	inch	124.6
Evaporation Capability	gal/h	
Gas		15.85
Electric		13.21
Steam		18.49
Ironing Speed	ft/min	4-49
Net Weight	lbs	
Gas/Electric	without folder	3137
	with folder	3497
Steam	without folder	3379
	with folder	3739
Crated Weight	lbs	
Gas/Electric	without folder	3876
	with folder	4290
Steam	without folder	4118
	with folder	4533
Machine Width	inch	161.5
Machine Depth	inch	46.2
Machine Height	inch	64.2
Feed Height	inch	40.6
Shipping Dimensions (WxDxH)	inch	
	without folder	167.3 x 45.5 x 71.9
	with folder	167.3 x 50.6 x 71.9
Motor Power	Hp	
Roller Motor		0.40
Extraction Motor		0.74
Exhaust Diameter	inch	5.1 (130)
Exhaust Air Flow	cfm	
Gas		564
Electric/Steam		634
Electric Heating	kW	
208/60/3		47.32
240/60/3		63
Gas Connection	inch	3/4 NPT
Gas Heating	BTU/h	
Natural		256,593
Propane		256,934
Gas Consumption	cfm	
Natural		4.69
Propane		12.66
Gas Pressure Operating Manifold	inch wc	
Natural		7
Propane		11
Steam Connection	inch	1
Steam Condensate Outlet	inch	3/4
Steam Heating	BTU/h	277,748
Steam Consumption	lbs/h	317
Steam Pressure	PSI	116
Safety Valve Connection	inch	1
Circuit Protection	Amps	
Gas/Steam	208-240/60/1	10
Electric	208/60/3	200
	240/60/3	200
Full Load	Amps	
Gas/Steam	208-240/60/1	6.1
Electric	208/60/3	137
	240/60/3	158

### FRONT VIEW

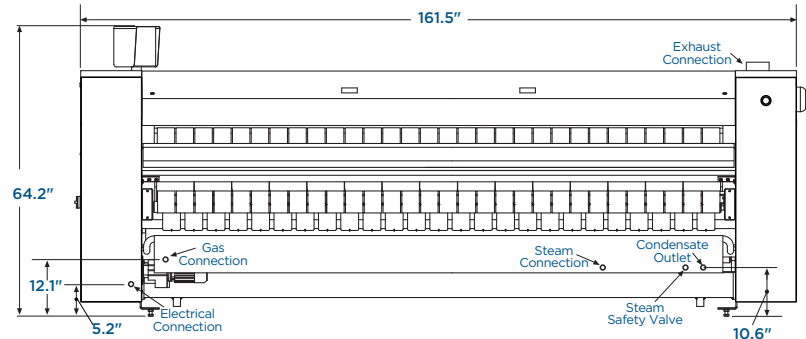

### TOP VIEW

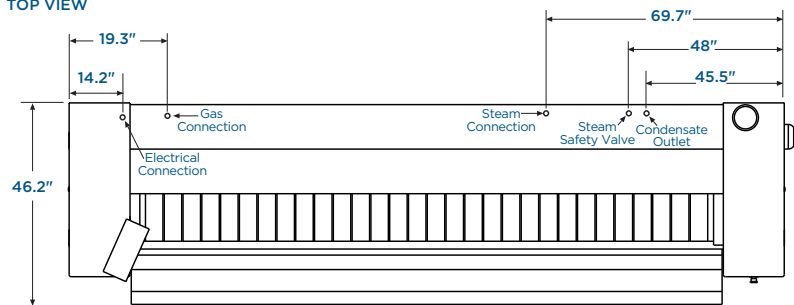

### AREA NEEDED FOR SERVICE

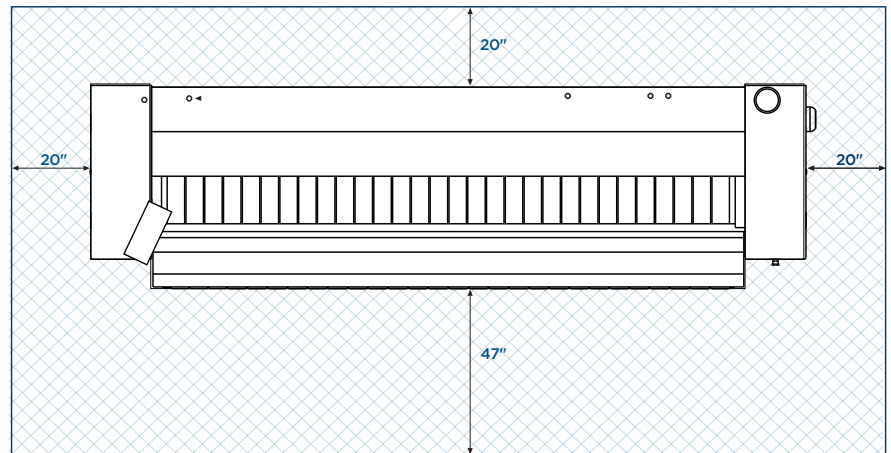

### SIDE VIEW

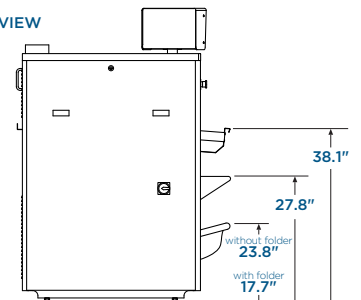

\* Specifications subject to change without notice or obligation. Contact Poseidon Textile Care Systems at (800) 482-3400 for dimensions not shown or for clarification.

poseidonwetcleaning.com • (800) 482-3400  
2329 Alger Drive, Troy, MI 48083

